

# AF75-OR-174 ABOVE FRAME ROLL-OFF CABLE HOIST



Tel: 800.285.0666 | sales@wastequip.com  
www.galbreathproducts.com



AF-OR model shown

Above Frame (AF) cable hoists are versatile enough to work with any truck chassis, suspension, exhaust system or fuel tank.

- » **75,000 lb. capacity**
- » **Tandem axle**

## Standard Features

### Ease of Operation

- Centered cab-mount Power Tower
- Plug n' Play wiring system
- Pintle-ready rear aprons
- Standard inside air control

### Safety

- Automatic front container spring-loaded locking system and rear container hold-downs
- Heavy-duty safety props
- Air-assist fold-up ICC bumper
- Backup alarm and hoist up alarm with signal light on dash
- Optional hoist up speed-limiting parameters

### Durability

- 3 micron filtration system with dual viscosity oil
- Two-part epoxy primer and paint\*
- Field-tested heavy-duty rear hinge
- Hoist frames are huck-bolted to chassis\*
- Shock-absorbing sub-frame
- Oil reservoir is filter cart ready
- LED lighting
- Lifetime warranty on frame and two-year warranty on hydraulics

### Quality

- Lean manufacturing, engineering, solid modeling, and stress analysis testing ensure quality, consistent product every time
- Customized engineering layouts based on customers' chassis ensure compatibility

\* Factory mount models

## Available Options

- Pintle hook applications
- Various fender options
- Rear ratchet straps
- Auxiliary hydraulic hook-ups
- Scale systems
- Pioneer Rack 'n Pinion tarping systems
- Lift axles
- Additional hydraulics
- Special safety lighting with strobes

# AF75-OR-174 ABOVE FRAME CABLE HOIST

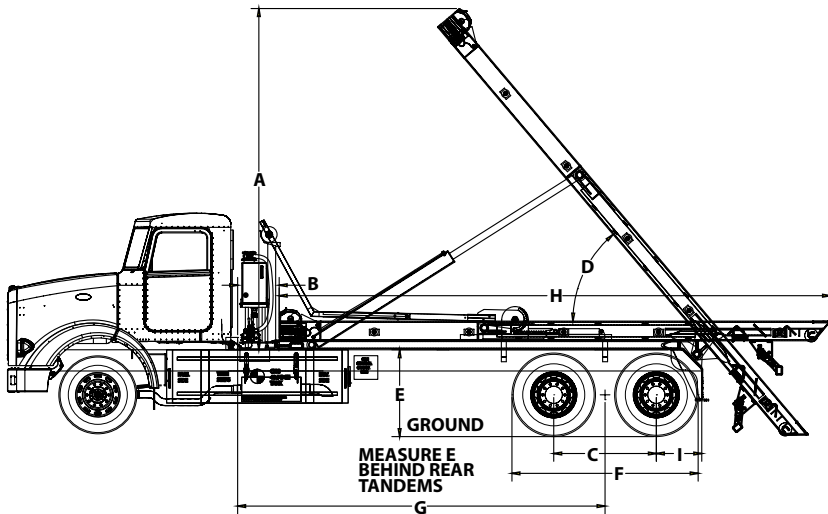

## HOIST FRAME DETAIL

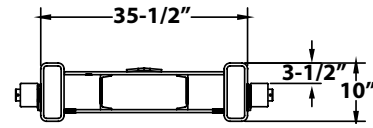

## SWIVEL CABLE END

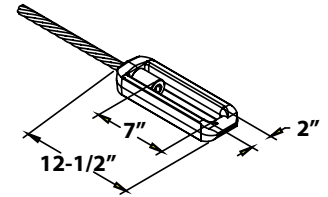

FEATURE	TANDEM AXLE
Recommended container size <sup>1</sup>	18-22'
Rated capacity <sup>2</sup>	75,000 lbs.
A - Height above truck frame <sup>3</sup>	173"
B - Back of Cab to Hoist <sup>4</sup>	18"
C - Axle spread	51-60"
D - Raised dump angle	50°
E - Top of truck frame to ground <sup>3, 5, 6</sup>	45"
F - Tire OD to OD	98"
G - Clear Cab to Trunnion (CT) (includes behind the cab tank on tarper mounting platform and Pioneer Rack'n Pinion tarper)	188"
H - Hoist length	282-1/2"
I - After frame	25"
Lift cylinders DA = double acting	6" x 3-1/2" x 73" DA
Lift cylinders shaft	2-3/4" solid
Winch cylinders DA = double acting	HD 7" x 4" x 80" DA
Approx. weight with standard features	8,482 lbs.

FEATURE	TANDEM AXLE
Hoist frame	10" x 4" x 1/2" - A500 Grade C Tubing with T1 3/8 x 3 wear strip on top of rail
Subframe	4" x 4" x 1/4" - A500 Grade C tubing
Rear wing plate	1/2" x 4" x 60" with 1/2" x 5" full supported bracket
Front stop	1-1/2" plate
Front safety lock	Automatic spring loaded
Hinge shaft	2-1/2" solid steel
Cable anchors	Wedge and ferrule
Cable end	Swaged end swivel eye
Rear hold-downs	3/4" plate located for standard ANSI-compliant containers
Operating pressure	3,600 psi
Hydraulic pump	Gear type, 37-1/2 GPM @ 1500 RPM
Hydraulic valve	2 spool / 45 GPM with safety bypass
Oil reservoir	47-gallon with 3 micron filter
Outboard supported rollers	4" O.D. with bronze bearings
Cable sheaves	10" O.D. with bronze bearings
Working points	Greasable

### Notes for chart above:

- 1 When recommending container lengths, weight distribution, fender interference and overhang are factors
- 2 Factory tested with recommended container length and water level load
- 3 Frame = top of truck chassis frame
- 4 Length is 18" if welding oil tank to tarper support, or 24" if unable to weld oil tank to the tarper support
- 5 Use 22.5" tires only; for larger tires, consult representative
- 6 Request additional tail length for spring suspensions higher than 45"

TRUCK REQUIREMENTS	
Chassis front axle	18,000 lbs. (minimum) capacity with power steering
Chassis rear axle	44,000 lbs. (minimum) capacity with walking beam suspension
Frame modulus	50,000 psi or more chassis frame - minimum section modulus = 24 in <sup>3</sup>
Torque required	383 foot pounds of torque



Tel: 877.468.9278 | sales@wastequip.com | www.galbreathproducts.com

Galbreath is a Wastequip brand. Wastequip is the leading North American manufacturer of waste and recycling equipment for collecting, processing and transporting recyclables and solid or liquid waste. © Wastequip January 2014. All rights reserved. Specifications subject to improvement without notice. Equipment displayed should be operated by properly trained personnel. Operators should become familiar with OSHA, ANSI and any other applicable standards or laws for using this equipment. Improper use, misuse, or lack of maintenance could cause injury to people and/or property. Photos used in the literature are illustrative only. We assume no liability or responsibility for proper training/operation of equipment not manufactured by Wastequip. We reserve the right to make changes at any time without notice. Information contained within this literature is intended to be the most accurate available at time of printing.