

LOADED CONTAINER HANDLER (LCH)

Galbreath[®]

Tel: 800.285.0666 | sales@wastequip.com
www.wastequip.com



Transport loaded containers at highway speeds safely, efficiently and cost-effectively with Galbreath's Loaded Container Handler.

Benefits

Improved safety

- Container bottom is fully supported by dual rails for added safety and stability
- Container sits ahead of rear axle for improved safety and handling
- Ratchet straps provide added container security
- No flagging of containers or additional lighting required
- Container remains level during transport to prevent waste spillage
- Pintle hook allows for use with trailers

Cost savings and efficiency

- Allows smaller trucks to be used for container pickup for fuel savings and reduced emissions
- Improved aerodynamic design reduces drag
- Joystick controls inside the cab replace lever controls for easy one-hand operation
- Convenient when used with a trailer because there is no rear overhang
- Can be used with front or rear load containers



Rear lights visible during transport to prevent the need for a light bar or flags.

LOADED CONTAINER HANDLER (LCH)

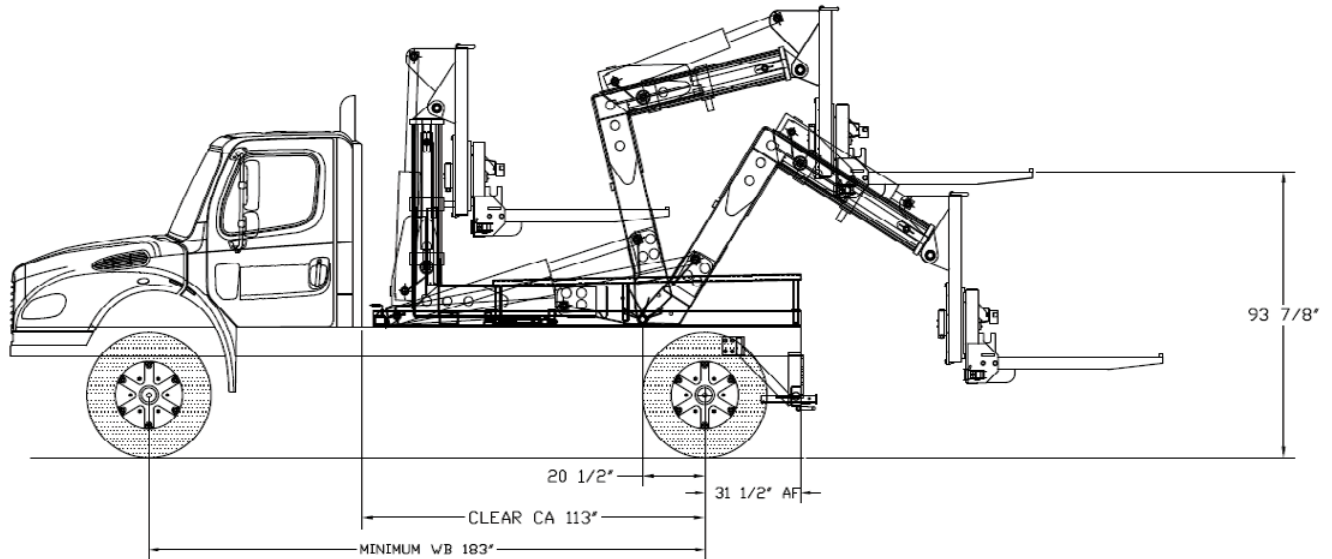

FEATURES

Standard

- Poly half round fenders
- Inside joystick control
- Bumper with LED lighting
- Pintle ready apron with Reese receiver hitch
- Ratchet retainer straps
- New rear load attachment
- Back up alarm
- Hoist up alarm with signal light
- Plug and play wiring

- Rotates to fully dump container into standard 30-yard open top
- Three (3) micron filtering system
- Outside four (4) spool manual controls
- Poly container bumper stops
- Two (2) lift cylinders for stability in operation
- Direct mount hydraulic gear pump - 23 gpm at 1,500 rpm, operating pressure 3,800 psi
- One year warranty

Options

- PTO for automatic or manual transmissions
- Work lights
- Steel or aluminum fenders
- Tool box
- Camera kit
- Air compressor for non-air trucks
- Factory mounting
- Lid holder and hinge rod holder
- Pintle hook
- Toter cart carrier behind the cab

Specifications

- Capacity - up to 8,000 lbs.*
- Stacking capability (various sizes)
 - Examples: two 4-yard or two 2-yard containers**
- Capable of dumping into a standard 30-yard open top
- ANSI compliant container sizes (capacity)
 - Front Load: 2 to 10 yard
 - Rear Load: 2 to 6 yard

* When using ANSI compliant front load or rear load containers in good working condition not to exceed the container manufacturer's load capacity rating or truck chassis center of gravity limitation. Contact Wastequip or your local Galbreath dealer for more information.

** On-road. Capable of carrying more containers for in-yard use.

Recommended Truck Chassis Specifications

Minimum chassis GVWR	25,900 lbs.
Front axle capacity	8,000 lbs.
Rear axle capacity	18,000 lbs.
Frame steel	50,000 psi (minimum)
Section modulus	15.5 in ³
Chassis wheelbase	183" (minimum)
Clear CA	113"
After frame	31 1/2"
LCH Weight:	4,990 lbs
Dual rear wheels	
Add 3' to CA for Toter cart carrier	
Add to CA for behind the cab storage	

Galbreath Galbreath is a Wastequip brand Tel: 800.285.0666 | sales@wastequip.com | www.wastequip.com

Wastequip is the leading North American manufacturer of waste and recycling equipment for collecting, processing and transporting recyclables and solid or liquid waste.

June 2010 © Wastequip, all rights reserved. Specifications subject to improvement without notice. Equipment displayed should be operated by properly trained personnel. Operators should become familiar with OSHA, ANSI and any other applicable standards or laws for using this equipment. Improper use, misuse, or lack of maintenance could cause injury to people and/or property. Photos used in the literature are illustrative only. We assume no liability or responsibility for proper training/operation of equipment not manufactured by Wastequip. We reserve the right to make changes at any time without notice. Information contained within this literature is intended to be the most accurate available at time of printing.

GAL001-052013