

ROLL-OFF CABLE HOISTS



Tel: 800.285.0666 | sales@wastequip.com | www.galbreathproducts.com

ABOVE FRAME SERIES

Above Frame (**AF**) cable hoists are versatile enough to work with any truck chassis, suspensions, exhaust systems and fuel tanks.

» **60,000 lb. capacity**

» **Tandem axle**

AF SERIES



AF-OR model shown

STANDARD FEATURES

Ease of Operation

- Centered cab-mount Power Tower
- Plug n' Play wiring system
- Pintle-ready rear aprons
- Standard inside air control

Safety

- Automatic front container spring-loaded locking system and rear container hold-downs
- Heavy-duty safety props
- Fold-up ICC bumper
- Backup alarm and hoist up alarm with signal light on dash
- Optional hoist up speed-limiting parameters

* **Factory mount models**

Durability

- 3 micron filtration system with dual viscosity oil
- Two-part epoxy primer and paint*
- Field-tested heavy-duty rear hinge
- Hoist frames are huck bolted to chassis*
- Shock-absorbing sub-frame
- Oil reservoir is filter cart ready
- LED lighting
- Lifetime warranty on frame and two-year warranty on hydraulics

Quality

- Lean manufacturing process, engineering, solid modeling and stress analysis testing ensure quality, consistent product every time
- Customized engineering layouts are created based on customers' chassis to ensure compatibility

AVAILABLE OPTIONS

- Pintle hook applications
- Various fender options
- Auxiliary hydraulic hook-ups
- Scale systems
- Pioneer Rack 'n Pinion tarping systems
- Lift axles
- Additional hydraulics
- Special safety lighting with strobes
- Wet kit

SPECIFICATIONS

OR Series

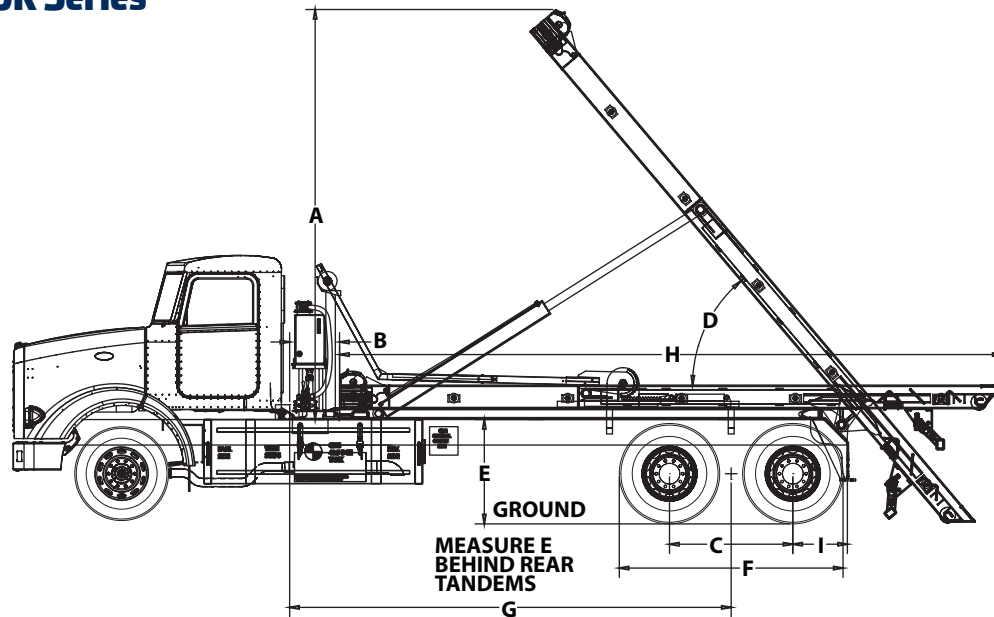

HOIST FRAME DETAIL

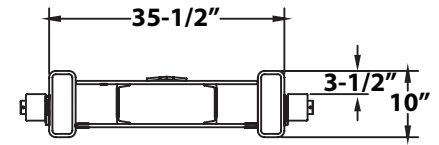

SWIVEL CABLE END

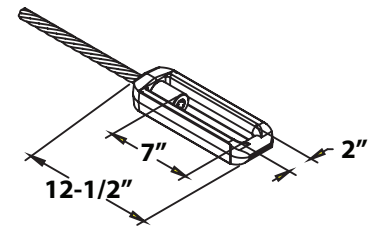

*Illustration applies to AF-OR style only.
See next page for other models.*

Notes for charts below:

- 1 When recommending container lengths, weight distribution, fender interference and overhang are factors
- 2 Factory tested with recommended container length and water level load
- 3 Frame = top of truck chassis frame
- 4 Length is 18" if welding oil tank to tarper support, or 24" if unable to weld oil tank to the tarper support
- 5 Use 22.5" tires only; for larger tires, consult representative
- 6 Request additional tail length for spring suspensions higher than 45"

	AF-OR-174	AF-OR-194	AF-IO-174	AF-IO-194
FEATURE	TANDEM AXLE	TANDEM AXLE	TANDEM AXLE	TANDEM AXLE
Recommended container size ¹	18-22'	20-24'	18-22'	20-24'
Rated capacity ²	60,000 lbs.	60,000 lbs.	60,000 lbs.	60,000 lbs.
A - Height above truck frame ³	173"	188"	173"	188"
B - Back of Cab to Hoist ⁴	18"	18"	18"	18"
C - Axle spread	51-60"	51-60"	51-60"	51-60"
D - Raised dump angle	50°	50°	50°	50°
E - Top of truck frame to ground ^{3, 5, 6}	45"	45"	45"	45"
F - Tire OD to OD	98"	98"	98"	98"
G - Clear Cab to Trunnion (CT) (includes behind the cab tank on tarper mounting platform)	188"	208"	188"	208"
H - Hoist length	282-1/2"	305-1/2"	282-1/2"	302-3/4"
I - After frame	25"	25"	25"	25"
Lift cylinders DA = double acting	6" x 3-1/2" x 73" DA	6" x 3-1/2" x 73" DA	6" x 3-1/2" x 73" DA	6" x 3-1/2" x 73" DA
Lift cylinders shaft	2-3/4" solid	2-3/4" solid	2-3/4" solid	2-3/4" solid
Winch cylinders DA = double acting	7" x 4" x 80" DA	7" x 4" x 90" DA	7" x 4" x 80" DA	7" x 4" x 90" DA
Approx. weight with standard features	7,882 lbs.	8,526 lbs.	8,378 lbs.	9,022 lbs.

FEATURES	TANDEM AXLE
Hoist frame	10" x 4" x 1/2" - A500 Grade C Tubing
Subframe	4" x 4" x 1/4" - A500 Grade C tubing
Front stop	1-1/2" plate
Front safety lock	Automatic spring loaded
Hinge shaft	2-1/2" solid steel
Cable anchors	Wedge and ferrule
Cable end	Swaged end swivel eye
Rear hold-downs	3/4" plate located for standard Wastequip containers
Operating pressure	3,200 psi
Hydraulic pump	Gear type, 37-1/2 GPM @ 1500 RPM
Hydraulic valve	2 spool / 45 GPM with safety bypass
Oil reservoir	47 gallon with 3 micron filter and fill
Outside rollers	4" O.D. with bronze bearings
Cable sheaves	10" O.D. with bronze bearings
Working points	Greasable

TRUCK SPECIFICATIONS	REQUIREMENTS
Chassis front axle	18,000 lbs. (minimum) capacity with power steering
Chassis rear axle	44,000 lbs. (minimum) capacity with walking beam suspension
Frame modulus	50,000 psi or more chassis frame - minimum section modulus = 24 in. ³
Torque required	383 foot pounds of torque

	AF-EX-174	AF-EX-194	AF-OX-174	AF-OX-194	AF-HH-174
FEATURE	TANDEM AXLE	TANDEM AXLE	TANDEM AXLE	TANDEM AXLE	TANDEM AXLE
Recommended container size ¹	18-22'	20-24'	18-22'	20-24'	18-22'
Rated capacity ²	60,000 lbs.	60,000 lbs.	60,000 lbs.	60,000 lbs.	60,000 lbs.
A - Height above truck frame ³	173"	188"	173"	188"	173"
B - Back of Cab to Hoist ⁴	18"	18"	18"	18"	18"
C - Axle spread	51-60"	51-60"	51-60"	51-60"	51-60"
D - Raised dump angle	50°	50°	50°	50°	50°
E - Top of truck frame to ground ^{3,5,6}	45"	45"	45"	45"	45"
F - Tire OD to OD	98"	98"	98"	98"	98"
G - Clear Cab to Trunnion (CT) (includes behind the cab tank on tarper mounting platform)	188"	208"	188"	208"	188"
H - Hoist length	242" / + 80"	262" / + 80"	282-1/2" / + 48"	305-1/2" / + 48"	238-3/4"
I - After frame	25"	25"	25"	25"	25"
Lift cylinders DA = double acting	6" x 3-1/2" x 73" DA	6" x 3-1/2" x 73" DA	6" x 3-1/2" x 73" DA	6" x 3-1/2" x 73" DA	6" x 3-1/2" x 73" DA
Lift cylinders shaft	2-3/4" solid	2-3/4" solid	2-3/4" solid	2-3/4" solid	2-3/4" solid
Winch cylinders DA = double acting	7" x 4" x 80" DA	7" x 4" x 90" DA	7" x 4" x 80" DA	7" x 4" x 90" DA	7" x 4" x 80" DA
Approx. weight with std. features	8,849 lbs.	9,133 lbs.	9,316 lbs.	9,600 lbs.	7,555 lbs.

HOIST DRAWINGS

IO Series

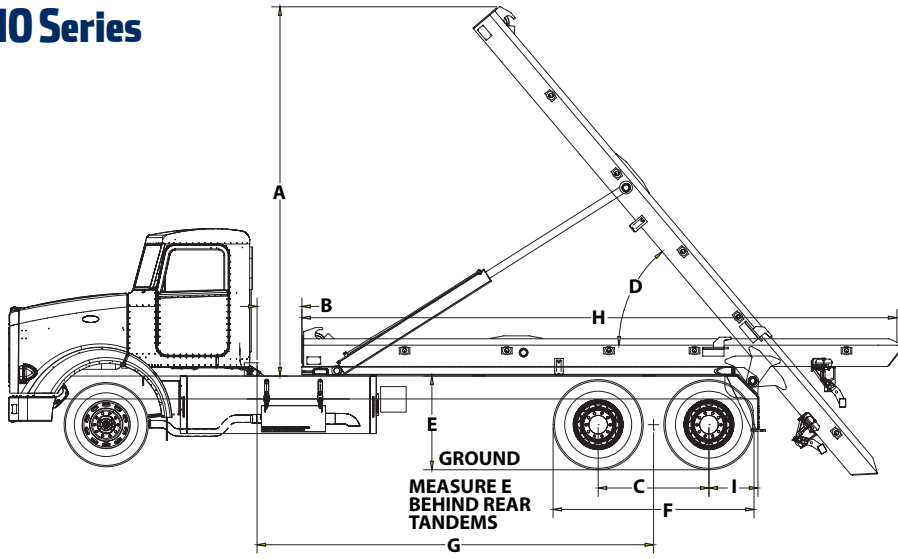

HOIST FRAME DETAIL

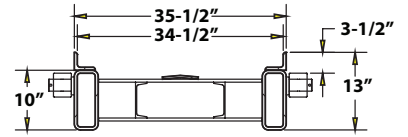

SWIVEL CABLE END

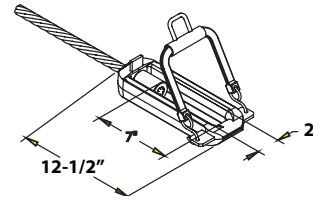

EX Series

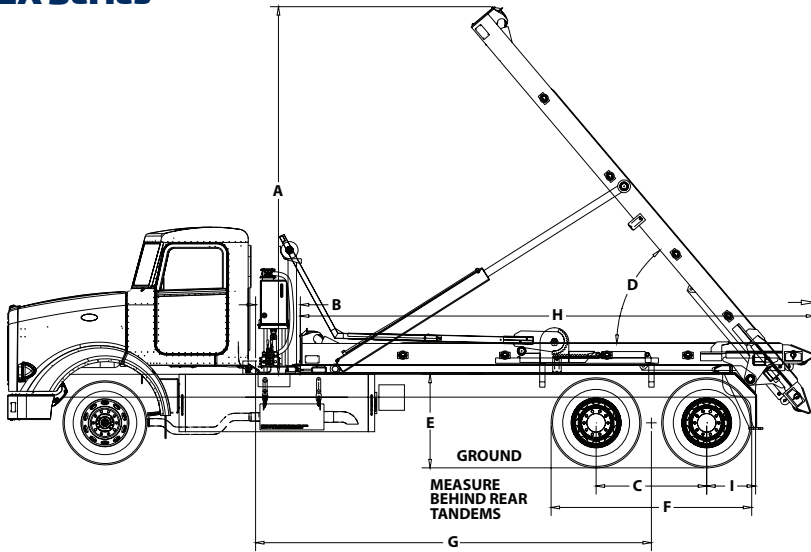

HOIST FRAME DETAIL

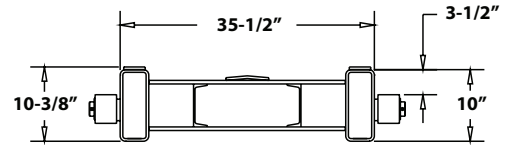

SWIVEL CABLE END

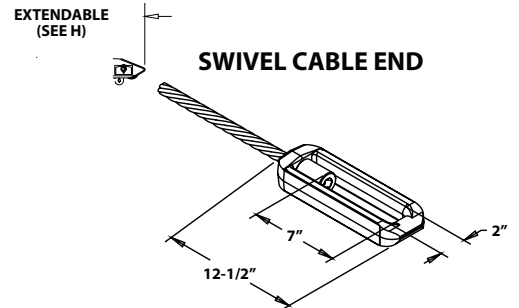

HH Series

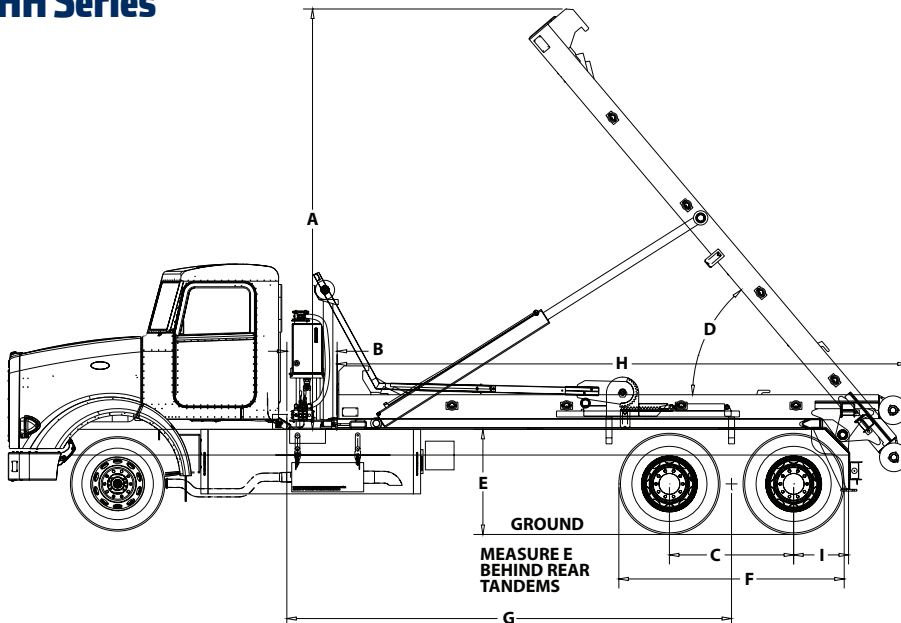

HOIST FRAME DETAIL

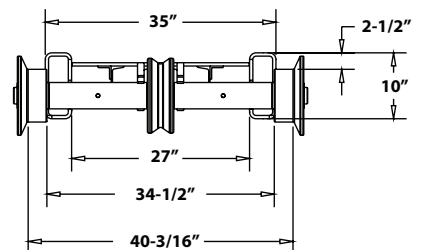

KNUCKLE CABLE END

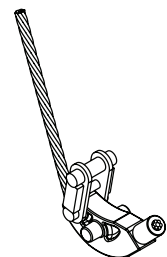

GALBREATH QUALITY

Standard Features



3 micron (pictured at right) filtration system with dual viscosity oil reduces contamination, required maintenance and down time



Automatic front container spring-loaded locking system and rear container hold-downs help ensure container remains in place



"Plug n' Play" wiring system eliminates crossed wires, loose connections, corrosion and splices; allows for easy light replacement



Oil reservoir is filter cart ready, reducing maintenance costs



Air assist ICC bumper



Hoist frames are huck bolted to chassis, providing unmatched strength and durability (factory mount only)

Available Options



Rear skid plate with outboard supported rollers



Optional rear ratchet straps on all cable models



Pintle ready rear aprons allow for the addition of a pintle hook and easy upgrade to a trailer package

AVAILABLE OPTIONS

- Pintle hook applications
- Various fender selections
- Auxiliary hydraulic hook-ups
- Scale systems
- Pioneer Rack 'n Pinion tarping systems

TRUCK SPECIFICATIONS

Tandem axle:

- Front axle: 18,000 lbs. (min.) capacity
- Rear axle: 44,000 lbs. (min.) capacity
- 50,000 psi or more chassis frame
- Minimum section modulus = 24 in.³

Additional information:

- Operating pressure is 3,200 psi and engine/transmission torque required = 383 ft. lbs.

CONTAINER REQUIREMENTS

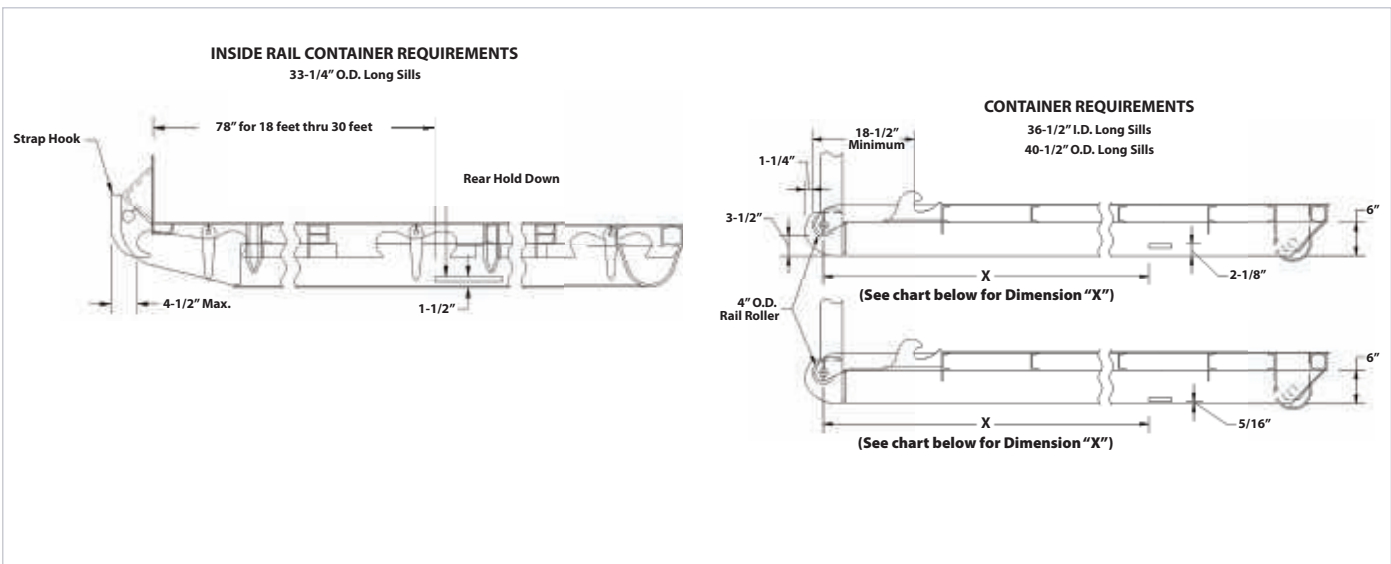

DIMENSION "X"*				
CONTAINER LENGTHS				
MODEL	18 ft.	20 ft.	22 ft.	24 ft.
All Models	173"	191"	191"	191"

* Dimension "X" is center of rail roller to front of rear hold-down
 NOTE: Tolerance for all models is +1" / -0" except where container lengths are not recommended or where more information is required.



Tel: 800.285.0666 | sales@wastequip.com | www.galbreathproducts.com

Wastequip is the leading North American manufacturer of waste and recycling equipment for collecting, processing and transporting recyclables and solid or liquid waste. © January 2014. Wastequip, all rights reserved. Specifications subject to improvement without notice. Equipment displayed should be operated by properly trained personnel. Operators should become familiar with OSHA, ANSI and any other applicable standards or laws for using this equipment. Improper use, misuse, or lack of maintenance could cause injury to people and/or property. Photos used in the literature are illustrative only. We assume no liability or responsibility for proper training/operation of equipment not manufactured by Wastequip. We reserve the right to make changes at any time without notice. Information contained within this literature is intended to be the most accurate available at time of printing.