

# CH8000 CONTAINER HANDLER



Tel: 800.285.0666 | sales@wastequip.com  
www.galbreathproducts.com

## Standard Features

- ▶ Handles front-load containers from 2 to 10 yards and rear-load containers from 2 to 6 yards
- ▶ Back-up alarms and hoist-up alarm with signal light
- ▶ Available with rotator for emptying containers; 200° rotator on "R" model
- ▶ Pintle or Reese-ready apron
- ▶ Direct-mount pump
- ▶ Oil reservoir (inside frame mount)
- ▶ Inside air controls
- ▶ Bumper with recessed LED lighting
- ▶ Poly fenders
- ▶ Retainer straps
- ▶ Black two-part epoxy paint\*

Galbreath container handlers are ideal for container delivery, pick-up, and placement, as well as moving containers around a yard.

**Available Models:**  
CH8000 (No Rotator)  
CH8000-R (With Rotator)



\*Model shown has inboard-mounted hydraulic tank.

## Options

- ▶ Air compressor for non-air trucks
- ▶ Toter platform
- ▶ Toolbox (side mount)
- ▶ Toolbox (behind cab)
- ▶ PTO manual or automatic transmission
- ▶ Wet spline pump/PTO upgrade
- ▶ Lid and rod holder (behind cab or side-mount)
- ▶ Pintle hook or Reese hitch set-up
- ▶ Work lights (multiple options)



Pintle-ready apron or reese hitch options available



Outside controls with safety cover



Extra CA can be added for storing lids, welders, toolbox, etc.

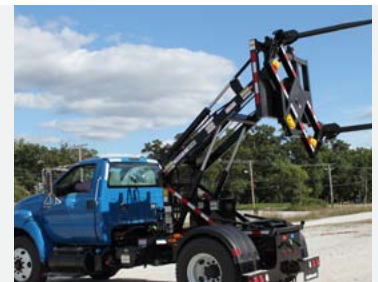

Rotating arms dump into a 30-yard open-top container

\* Factory mount

# CH8000 CONTAINER HANDLER

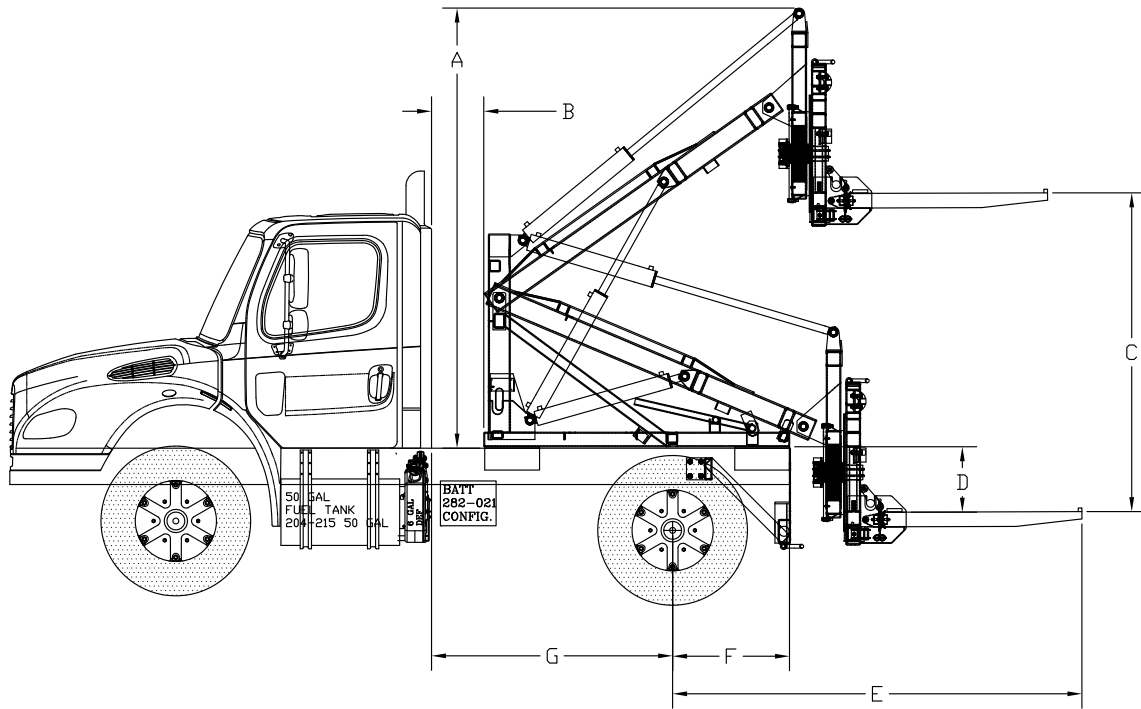

## CH8000

A = 122-11/16"  
 B = 14-5/16"  
 C = 92-3/16"  
 D = 11-5/8"  
 E = 106-3/4"  
 F = 32"  
 G = 66" min\*

## CH8000-R

A = 120-1/2"  
 B = 14-5/16"  
 C = 87-1/4"  
 D = 17-7/8"  
 E = 112-1/16"  
 F = 32"  
 G = 66" min\*

## SPECIFICATIONS

<b>Container Size</b>	2 to 10 yard (front-load) 2 to 6 yard (rear load)
<b>Rated Capacities*</b>	8,000 lbs. (lifting) 4,000 lbs. (hauling) 4,000 lbs. (rotating)
<b>Ratchet / Hold Down System</b>	Retainer straps
<b>Air Controls</b>	Inside air controls for conventional cab; 2 spool standard (non-rotator) or 3 spool (rotator)
<b>Lighting</b>	LED lighting
<b>Safety</b>	Hoist-up alarm with signal light
<b>Fenders &amp; Bumpers</b>	Poly with standard LED light bumper
<b>Frame Assembly</b>	5" x 3"
<b>Finish / Paint</b>	Two-part epoxy black primer**
<b>Other</b>	Direct mount pump Oil reservoir (inside frame mount) Outside 2 or 3 spool valve Rear load attachment Pintle or Reese-ready apron

Cans must be flagged during the day or lighted when dark.

\* Add 36" for Toter cart platform. Add 24" for behind-the-cab toolbox or lid holder. Typical CA is 80" without Toter cart platform

\* The above capacity ratings are based on container's center of gravity out 24" on forks. With a loaded container, travel is limited to 20 MPH on a smooth, level terrain. **!WARNING!** Increased speeds and rougher terrain will substantially reduce the rated capacity of the container handler. Do not exceed rated capacity of (1) container handler, (2) container, or (3) truck. Doing so may result in damage to equipment and/or injury to persons.

\*\* Factory mount



Tel: 800.285.0666 | sales@wastequip.com | www.galbreathproducts.com

Galbreath is a Wastequip brand. Wastequip is the leading North American manufacturer of waste and recycling equipment for collecting, processing and transporting recyclables and solid or liquid waste. © 2014 Wastequip, all rights reserved. Specifications subject to improvement without notice. Equipment displayed should be operated by properly trained personnel. Operators should become familiar with OSHA, ANSI and any other applicable standards or laws for using this equipment. Improper use, misuse, or lack of maintenance could cause injury to people and/or property. Photos used in the literature are illustrative only. We assume no liability or responsibility for proper training/operation of equipment not manufactured by Wastequip. We reserve the right to make changes at any time without notice. Information contained within this literature is intended to be the most accurate available at time of printing.

GAL006-052014