

ROLL-OFF CABLE HOISTS



Tel: 800.285.0666 | sales@wastequip.com | www.wastequip.com

Extendable Tail (EX) cable hoists are ideal for areas with clearance issues that require a low loading height.

- » **30,000 to 60,000 lb. capacity**
- » **Single and tandem axle**



EX SERIES

STANDARD FEATURES

Ease of operation

- Centered cab-mount Power Tower
- Plug n' Play wiring system
- Pintle ready rear aprons
- Standard inside air control

Safety

- Automatic front container spring-loaded locking system and rear container hold-downs
- Heavy-duty safety props
- ICC bumper on select models when required
- Backup alarm and hoist up alarm with signal light on dash
- Optional hoist up speed-limiting parameters

* **Factory mount models**

Durability

- 3 micron filtration system with dual viscosity oil
- Two part epoxy primer and paint*
- Field tested heavy duty rear hinge
- Hoist frames are huck bolted to chassis*
- Shock-absorbing sub-frame
- Oil reservoir is filter cart ready
- LED lighting
- Lifetime warranty on frame and two-year warranty on hydraulics

Quality

- Lean manufacturing process, along with engineering, solid modeling and stress analysis testing, ensure quality, consistent product every time
- Customized engineering layouts are created based on customers' chassis to ensure compatibility

AVAILABLE OPTIONS

- Reverse cylinder mount
- Pintle hook applications
- Various fender selections
- Auxiliary hydraulic hook-ups
- Scale systems
- Pioneer Rack 'n Pinion tarping systems

GALBREATH QUALITY

Standard Features



3 micron (pictured at right) filtration system with dual viscosity oil reduces contamination, required maintenance and down time



Automatic front container spring-loaded locking system and rear container hold-downs help ensure container remains in place



"Plug n' Play" wiring system eliminates crossed wires, loose connections, corrosion and splices; allows for easy light replacement



Oil reservoir is filter cart ready, reducing maintenance costs



Air assist ICC bumper



Hoist frames are huck bolted to chassis, providing unmatched strength and durability (factory mount only)

Available Options



Rear skid plate with outboard supported rollers



Optional rear ratchet straps on all cable models



Pintle ready rear aprons allow for the addition of a pintle hook and easy upgrade to a trailer package

SPECIFICATIONS

EX Series

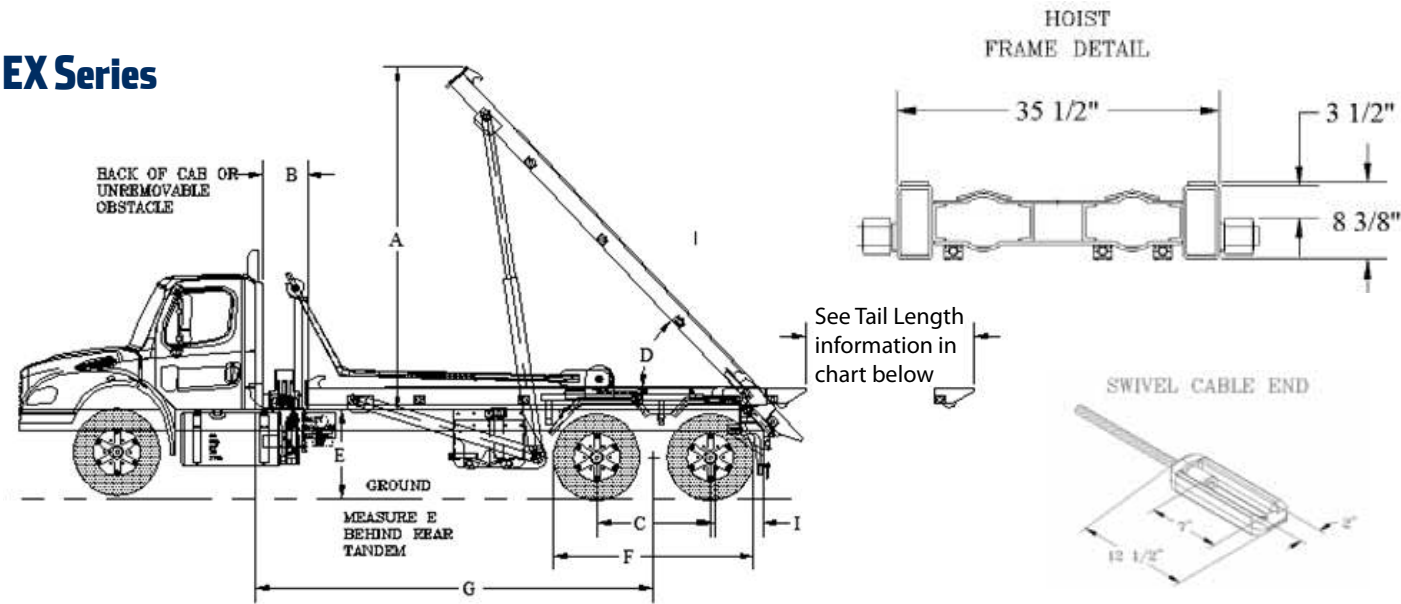

Notes for chart below:

- 1 When recommending container lengths, weight distribution, fender interference and overhang are factors
- 2 Factory tested with recommended container length and water level load
- 3 Frame = top of truck chassis frame
- 4 This distance does not allow for a behind-the-cab oil reservoir, tarper platform and room to add a tarper. Must add distance for these items
- 5 Using 22.5" tires only. For larger tires, consult representative

FEATURES	SINGLE AXLE	TANDEM AXLE
Hoist frame	8" x 3" x 3/8" A500 grade C tubing	8" x 4" x 3/8" A500 grade C tubing
Subframe	4" x 3" x 1/4" A500 grade C tubing	3" x 2" x 3/16" A500 grade C tubing
Front stop	1 1/2" plate	1 1/2" plate
Front safety lock	Automatic spring loaded	Automatic spring loaded
Hinge shaft	1 1/2" solid steel	2 1/2" solid steel
Cable anchors	4 cable clamps	4 cable clamps
Cable end	Pear eye	Swaged end swivel eye
Rear hold downs	1/2" plate located for standard Wastequip containers	3/4" plate located for standard Wastequip containers
Operating pressure	1,850 psi	1,850 psi
Hydraulic pump	Gear type 17.5 gpm @ 1500 rpm	Gear type 35 gpm @ 1500 rpm
Hydraulic valve	2 spool / 25 gpm with safety bypass	2 spool / 45 gpm with safety bypass
Oil reservoir	20 gallon with 25 micron filter & fill	50 gallon with 25 micron filter & fill
Outside rollers	4" O.D. with bronze bearings	4" O.D. with bronze bearings
Cable sheaves	10" O.D. with bronze bearings	10" O.D. with bronze bearings
Working points	Greasable	Greasable
Chassis front axle	9,000 lbs. (min) capacity with power steering	18,000 lbs. (minimum) capacity with power steering
Chassis rear axle	22,000 lbs. capacity (minimum)	44,000 lbs. capacity (minimum)
Frame modulus	24.3 in ³	33.3 in ³
Torque required	103 foot pounds of torque	248 foot pounds of torque

	U3-EX-156	U5-EX-174	U5-EX-194	U5-0X-174	U5-0X-194	U5-IX-174	U5-IX-194
FEATURE	SINGLE AXLE	TANDEM AXLE	TANDEM AXLE	TANDEM AXLE	TANDEM AXLE	TANDEM AXLE	TANDEM AXLE
Recommended container size ¹	14-20'	18-22'	20-24'	18-22'	20-24'	18-22'	20-24'
Rated capacity ²	30,000 lbs.	60,000 lbs.	60,000 lbs.	60,000 lbs.	60,000 lbs.	60,000 lbs.	60,000 lbs.
A - Height above truck frame ³	156 5/16"	162"	180 9/16"	162 1/4"	180 1/2"	163 7/16"	181 11/16"
B - Back of cab to hoist ⁴ (add 12" for tarper or hard plumbing)	6"	6"	6"	6"	6"	6"	6"
C - Axle spread	N/A	51-55"	51-55"	51-55"	51-55"	51-55"	51" - 55"
D - Raised dump angle	51°	47°	48°	47°	48°	47°	48°
E - Top of truck frame to ground ^{3,5}	42"	46"	46"	46"	46"	46"	46"
F - Tire OD to OD	N/A	96" max	96" max	96" max	96" max	96" max	96" max
G - Clear Cab to Trunnion (CT) (add 12" for tarper or hard plumbing)	156"	174"	194"	174"	194"	174"	194"
H - Hoist length	205 5/8" ⁶	237" ⁷	257" ⁷	279 1/4" ⁷	299 1/4" ⁷	256 1/4" ⁶	276 1/4" ⁶
I - After frame	37 1/4"	23"	23"	23"	23"	23"	23"
Lift cylinders DA = double acting DAT = double acting telescopic	5" x 3" x 54" DA	6" x 4" x 72" DA	6-5" x 114" DAT	6" x 4" x 72" DA	6-5" x 114" DAT	6" x 4" x 72" DA	6-5" x 114" DAT
Lift cylinders shaft	1 1/2" solid	2 1/2" solid	2 1/2" solid	2 1/2" solid	2 1/2" solid	2 1/2" solid	2 1/2" solid
Winch cylinders DA = double acting	5" x 3" x 66" DA	7" x 4" x 80" DA	7" x 4" x 90" DA	7" x 4" x 80" DA	7" x 4" x 90" DA	7" x 4" x 80" DA	7" x 4" x 90" DA
ICC bumper	Optional	Optional	Optional	Standard	Standard	Standard	Standard
Tail length (fully extended)	Add 60"	Add 80"	Add 80"	Add 60"	Add 60"	Add 60"	Add 60"
Approx. weight with standard features	5,232 lbs.	7,117 lbs.	7,190 lbs.	7,256 lbs.	7,321 lbs.	7,200 lbs.	7,310 lbs.

HOIST DRAWINGS

OX Series

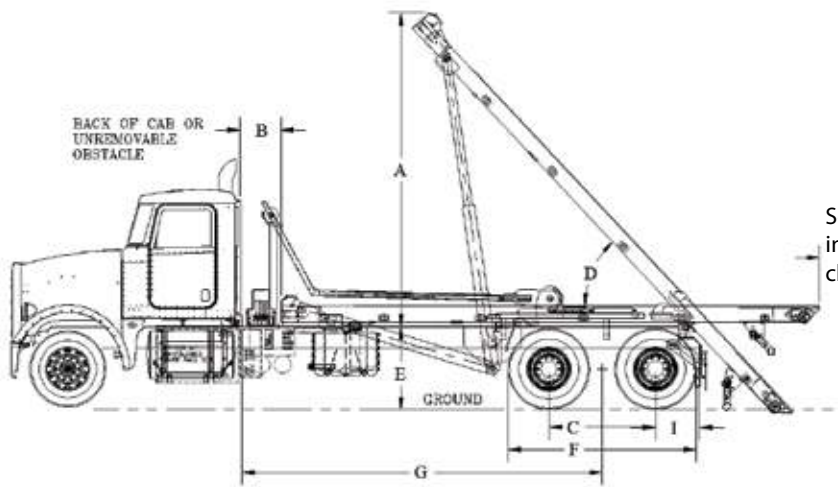

HOIST
FRAME DETAIL

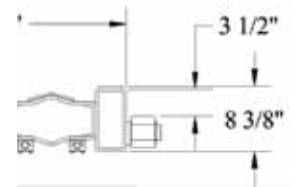

See Tail Length
information in
chart at left

SWIVEL CABLE END

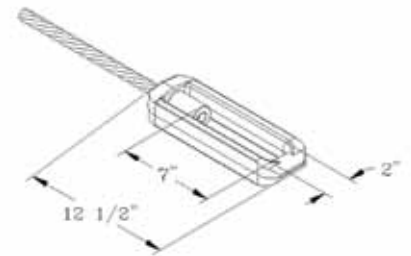

IX Series

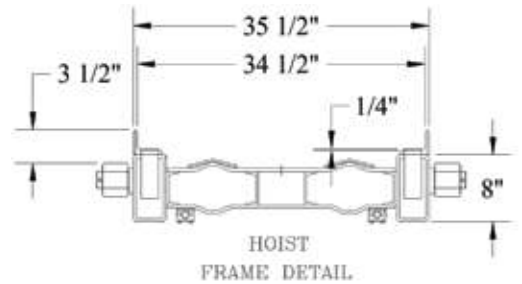
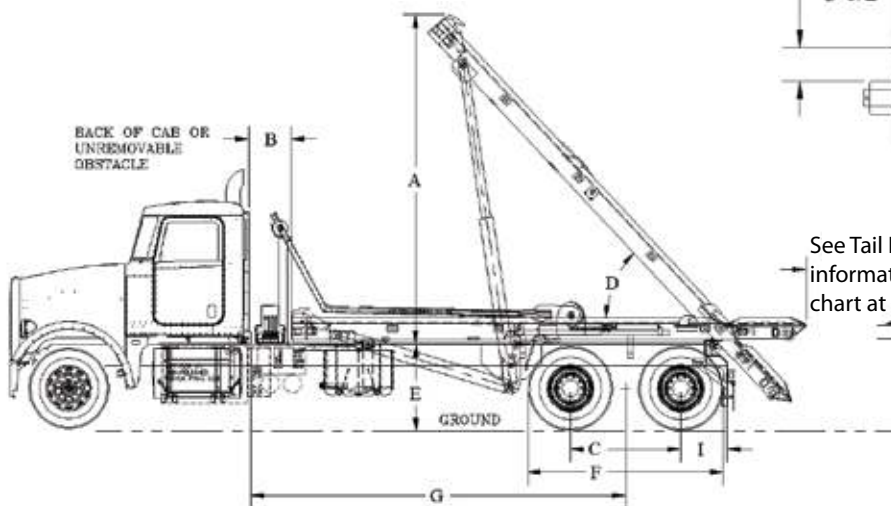

See Tail Length
information in
chart at left

SWIVEL CABLE END

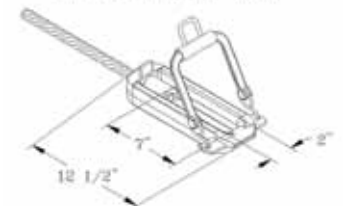

AVAILABLE OPTIONS

- Reverse cylinder mount
- Pintle hook applications
- Various fender selections
- Auxiliary hydraulic hook-ups
- Scale systems
- Pioneer Rack 'n Pinion tarping systems

TRUCK SPECIFICATIONS

Single axle:

- Front axle: 9,000 lbs. (min.) capacity
- Rear axle: 22,400 lbs. (min.) capacity
- 50,000 psi or more chassis frames
- Minimum section modulus = 17.5 in.³

Tandem axle:

- Front axle: 18,000 lbs. (min.) capacity
- Rear axle: 44,000 lbs. (min.) capacity
- 50,000 psi or more chassis frames
- Minimum section modulus = 24 in.³

CONTAINER REQUIREMENTS

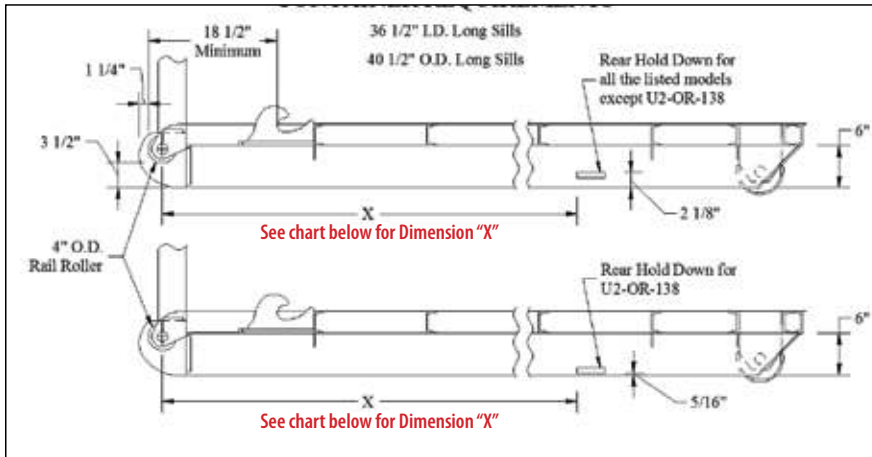

DIMENSION "X"*								
CONTAINER LENGTHS								
MODEL	12 ft.	13 ft.	14 ft.	15 ft.	16 ft.	17 ft.	18 ft.	19 ft. +
All (except U2-EX/ IO/OR-138 & U3-EX/ IO/OR-156)	Additional info. needed	145 1/2"	145 1/2"	149"	149"	173"	173"	191"
U2-EX/IO/OR-138	Length not recom- mended	Length not recom- mended	158"	158"	158"	158"	158"	Length not recom- mended
U3-EX/IO/OR-156	Length not recom- mended	Length not recom- mended	149"	173"	173"	173"	173"	173"

* Dimension "X" is center of rail roller to front of rear hold down

NOTE: Tolerance for all models is +1" / -0" except where container lengths are not recommended or where more information is required.



Tel: 800.285.0666 | sales@wastequip.com | www.wastequip.com

Wastequip is the leading North American manufacturer of waste and recycling equipment for collecting, processing and transporting recyclables and solid or liquid waste. September 2012 © Wastequip, all rights reserved. Specifications subject to improvement without notice. Equipment displayed should be operated by properly trained personnel. Operators should become familiar with OSHA, ANSI and any other applicable standards or laws for using this equipment. Improper use, misuse, or lack of maintenance could cause injury to people and/or property. Photos used in the literature are illustrative only. We assume no liability or responsibility for proper training/operation of equipment not manufactured by Wastequip. We reserve the right to make changes at any time without notice. Information contained within this literature is intended to be the most accurate available at time of printing.